

INSTRUCTION MANUAL

ASSEMBLY AND OPERATION

Cadence Profiling Beds



Index

Index	2
Foreword	5
models.....	6
1. General information	7
1.1 Explanation of the symbols used	7
1.2 Explanation of the designated groups of persons.....	8
2. Intended purpose	10
2.1 Intended use (application environment).....	10
2.2 Unauthorised use.....	10
3. Safety instructions	11
3.1 General safety instruction	11
3.2 Safety instructions for the operator.....	12
3.3 Safety instructions for the user.....	12
3.4 Cleaning and disinfection.....	13
3.5 Maintenance and repair.....	13
3.6 Accessories.....	14
3.7 Storage.....	14
3.8 Useful life and disposal.....	14
5. Assembly and commissioning	16
5.1 Assembly of Erector with triangle handle (accessory).....	16
5.2 Mounting the bed extension (Accessories).....	17
5.3 Protector (Accessories).....	20
5.4 Assembly of the 2-part split aluminium side rails (Accessories).....	21
5.5 Assembly of the 3-part split steel side rails (Accessories) 5.6.....	23
Commissioning	25
6. Functional description	26

Index

6.1	Technical overview.....	26
6.2	Handset with locking function.....	27
6.3	Locking function for handset.....	28
6.4	Operation of the side rails.....	29
6.4.1	The non-split side rail.....	29
6.4.2	The 2-part aluminium side rails.....	30
6.4.3	The 3-part steel side rail.....	31
6.5	Operation of the bed extension.....	32
6.6	Operating the central brake.....	33
6.7	Emergency lowering.....	33
6.7.1	Emergency lowering via integrated 9V battery (electric).....	33
6.7.2	Battery change.....	33
6.7.3	Emergency lowering of the backrest (manual).....	34
6.7.4	Trendelenburg / Antitrendelenburg function (option)	35
6.7.5	comfort seating position.....	36
6.7.6	lowest position.....	36
6.7.7	Staff control panel (accessories).....	37
7.	Care, cleaning and disinfection	38
8.	Cause and remedy of malfunctions	39
9.	Maintenance	40
9.1	Bases	40
9.2	Maintenance schedule	41
9.3	Check of first-error safety by means of integrated locking function in the handset.....	43
10.	Warranty.....	44
11.	Useful life and disposal.....	45
12.	Technical specifications.....	46

Index

- 12.1 Technical data (mechanical)..... 46
- 12.3 Technical data Environment..... 47
- 12.4 Classification..... 47
- 12.5 Weights of the individual components..... 47
- 12.6 Identification plates..... 48
- 12.7 Information on electromagnetic compatibility 49
- 13. Declaration of conformity..... 52

Foreword

Dear customer,

The team from Harvest Healthcare would like to thank you for the trust you have placed in our Cadence profiling bed range. By choosing to purchase a profiling bed from Harvest Healthcare, you receive a highly functional product that meets the highest safety standards.

With your new profiling bed, we can guarantee optimal lying comfort.

All beds are carefully checked by our staff before delivery.

The profiling bed delivered to you left our premises in perfect condition.

When you receive the bed, the responsibility for its proper and intended operation also passes to you at the same time.

These instructions for use inform you as the operator and your users in their daily work about the functioning and safe handling of the profiling bed.

Please keep the instructions for use at hand near the bed at all times.

We are convinced that our product will make a positive contribution to your care.

Best regards

Your Harvest Healthcare Team

Please read and observe these operating instructions before each use! If the bed changes ownership, please pass these instructions for use to the new owner.



Cadence Comfort with V type headboard and footboard

Lying surface 90 cm x 200 cm with wooden side rails



Cadence Comfort with V type headboard and footboard

Lying surface 90 cm x 200 cm with 2-part split aluminium side rails



Cadence Select

Lying surface 90 cm x 200 cm with lower headboard and footboard with 2-part split aluminium side rails



Cadence Select

Lying surface 90 cm x 200 cm with 3-part split steel side rails

1. General information

Before the first use:

Read these instructions for use carefully and in full before first use.

Please pay particular attention to the various safety instructions. The bed should be cleaned and disinfected before first use and before each reuse.



Harvest Healthcare beds carry the CE mark. The beds meet the requirements for safety and functionality. The Cadence bed range has been tested according to international standards, which include the safety requirements for medical devices.

However, these safety requirements can only be met if the user ensures that the bed (including its accessories) is in proper condition before using the profiling bed.

Please note the Medical Device Operator Ordinance (MPBetreibV, 2021).

1.1 Explanation of the symbols used

In these operating instructions, important information is indicated by the following symbols:



Read information with this symbol carefully and observe it urgently. This information is relevant to safety



This symbol warns of dangerous voltage. There is a danger to life!



This symbol warns of general dangers. There is danger to life and health.



Mark of conformity according to Medical Devices Regulation (EU) 2017/745



manufacturing date



Manufacturer of the medical device



medical device



Serial number

1. General information

IPX4

Protection of electrical equipment against splashing water



Symbol for device of protection class II, double protective insulation



Symbol for type B application part according to IEC 60601-1



The nursing bed may only be used indoors.



The product must be collected separately in the European Union. Disposal with normal household waste is not permitted.



Symbol for DC



Symbol for AC



Symbol for safe working load



Symbol for maximum patient weight



Symbol for reading instruction manual

1.2 Explanation of the designated groups of persons

Operator

The operator of a medical device is any natural or legal person who is responsible for the operation of the health facility in which the medical device is operated or used by its employees. Contrary to sentence 1, the operator of a medical device which is owned by a member of the medical profession or the medical industry and which is brought into a health facility by this member for use is the relevant member of the medical profession or the medical industry. A person is also considered to be an operator if they keep medical devices ready for use outside of health facilities in his company or facility or in public space. [§2, paragraph 2, MPBetreibV, 2021]

Requirements to be met by the operator

- Please note that for you as the operator of this medical device, the requirements of the Medical Device Operator Ordinance (MPBetreibV, 2021) are binding.
- The Cadence bed is a medical device and may only be operated and used in accordance with its intended purpose, the regulations of the MPBetreibV, the relevant legal regulations as well as the generally recognised rules of technology.
- Only instruct persons to use this medical device who have the necessary training or knowledge and experience and who have been instructed in the medical device to be used.
- Instruct the user in the proper handling of this medical device and document the instruction in an appropriate form.

1. General information

- A combination with other medical devices (including accessories) or with other objects may only be operated and used if they are suitable for use in this combination, taking into account the intended purpose and the safety of patients, users, employees or third parties.

User

The user is anyone who uses a medical device on a patient within the scope of the Medical Device Operator Ordinance (MPBetreibV). [§2, Para. 3, MPBetreibV, 2021]

User requirements

- Use the Cadence bed range only as intended and in accordance with these instructions for use.
- Only use this product if you have been properly instructed in its use and have the necessary training or knowledge and experience (e.g. nursing staff).
- Before using the profiling bed, make sure that it is in good working order and condition.
- Observe the Instruction Manual and other safety-related information enclosed.
- If suspected serious events occur in connection with the Cadence bed range, they must be reported to Harvest Healthcare and the responsible federal authority. Serious incidents occurring in other contracting states of the Agreement on the European Economic Area must be reported to the competent authorities of this state.
- Suspected serious event means an event that cannot be ruled out as being due to an undesirable side effect of a product, a malfunction, deterioration in the properties or performance of a product, including application errors due to ergonomic features or an inadequacy of the information provided by the manufacturer is based. Such a suspected serious event can have led directly or indirectly to death, to a temporary or permanent serious deterioration in the state of health of a patient, user or other person, as well as to a serious risk to public health (refer to the Ordinance on the Reporting of Suspected serious incidents with medical devices as well as for the exchange of information between the responsible authorities - MPAMIV).

Patient / Resident

In these instructions for use, a patient is defined as a person who is in need of nursing care due to his or her illness, disability or age and is lying in a nursing bed.

requirements for the patient / resident

It is possible for the patient lying in bed to independently operate the electrical adjustment functions of the bed via the hand switch if he has been instructed in the use of the bed and is mentally and physically able to do so. Independent use of the Cadence bed by the patient therefore requires that the patient can carry out the adjustment functions safely and specifically using the hand control and can also free himself from dangerous situations.

Qualified personnel

The operator's employees who are authorised to deliver, assemble, dismantle and transport the bed on the basis of their training or instruction are referred to as qualified personnel. In addition, these persons are instructed in the instructions for cleaning and disinfecting the bed.

2. Intended purpose

2.1 Intended use (application environment)

The Cadence profiling beds are designed for the accommodation of adults with a body height from 150cm and a body weight from 40kg to max. 200kg. They are suitable for use in senior residences, nursing homes and in home care - i.e. in application environments 3 and 4 - and may only be operated under the operating conditions described in these operating instructions.

The Cadence profiling beds are designed to alleviate or compensate for disability or incapacity and to facilitate working conditions for the caregiver. Any other use is considered improper and is excluded from possible liability. Attention: The Cadence profiling beds are not designed for use in hospitals. They are not EX-protected and must not be operated in hazardous areas.

The Cadence profiling beds may only be used in dry interior rooms. They are only suitable for transporting patients within the patient's room and with the lying surface adjusted to the lowest horizontal position.

The Cadence profiling beds has no connection option for equipotential bonding.

You must therefore take this into account when combining the Cadence bed with other electrical medical devices or with other mains-operated products.

The operator, as a competent person, must check whether the corresponding combination of the Cadence bed with other electrical devices is safe during the service life and no unacceptable risks can occur.

The operator of the medical devices is responsible for ensuring that the combination of the devices meets the requirements of IEC 60601-1.

Non-electrical medical devices must comply with the IEC or ISO safety standards applicable to these devices if they are to be used / combined with the bed.

If cables from other devices are routed in the Cadence bed, precautions must be taken to prevent these cables from being crushed between parts of the bed.

Take into account the information and safety instructions in the instructions for use of the electrical devices that you want to combine with the Cadence bed range (e.g. anti-decubitus alternating pressure systems, feeding systems, infusion pumps, lamps, etc.) as well as the requirements of the IEC 60601-1 standard (in the current Version).

In this case, all Cadence bed functions must be deactivated for safety reasons for the duration of use via the integrated locking device on the hand control.

2.2 Unauthorised use

All uses deviating from the intended use, which can then also lead to hazards.

These include, for example:

- Loading of the nursing bed beyond the permissible safe working load (see para. 12.1 and type plate on bed frame)
- Operation of the bed by the patient or occupant who has not received any instruction.
- Use of the nursing bed for children
- Attempting to move the profiling bed while the brakes are applied.
- Use of the nursing bed on a non-horizontal surface (max. inclination 5°)

3. Safety instructions

3.1 General safety instructions

Possible potential dangers which may occur despite proper operation must be pointed out separately during the instruction. Before initial operation, the user/care personnel must read the operating instructions carefully and in detail.



No objects or body parts of persons may be in the movement area of the bed while the adjustment functions are being actuated. Risk of crushing!



Ensure that the bed cannot be operated by children playing and that there are no pets under the bed when the bed is adjusted.



If the psychological or mental condition of the patient requires it, the hand control must be locked via the lock switch on the back of the hand control (nurse key). The locking function is described in detail in par. 6.3. For this patient group it may also be necessary to place the hand control outside the patient's access area in order to avoid the danger of strangulation by cables.



Bed adjustments may only be carried out by instructed persons or in the presence of an instructed person.



If a possibly necessary side guard (side rail) is used, pay particular attention to the following instructions:



- Only use side rails approved by Harvest Healthcare as optional accessories. The permissible dimensions can be found in chapter 12.1.
- The use of incompatible side rails is not permitted and can lead to hazards, e.g. due to trapping.
- The distance between two side rails lying one above the other or between the lower edge of the lower side rail and the lying surface must not exceed 12 cm.
- Only instructed personnel may operate the side rails.
- Side rails may only be fully raised and locked or fully lowered.
- When lowering the side rails, take care not to drop them.
- **No parts of the patient's body may protrude over the lying surface or touch the side rails while the adjustment function is being actuated.**
- The side rails only offer protection against rolling out when the backrest and knee adjustment are in the horizontal position.
- Under no circumstances should side rails be used improperly (e.g. for climbing over or supporting).
- The distance between the top edge of the side rail and the top of the mattress in non-compressed condition must be at least 22 cm. If the distance is less than the specified minimum, use a side rail elevation.
- When in use, the side rails must not remain in a diagonal position.



Before moving the Cadence bed, disconnect the mains plug from the socket and ensure that the mains plug does not rub against the floor while moving it.



The mains plug should always be accessible so that in an emergency the device can be disconnected from the mains supply by pulling it out of the socket.

The mains cable must be exposed and must not be trapped, as it is carried with the height adjustment of the bed. Otherwise the mains cable may be torn out of its strain relief and damaged. In addition, the mains plug can be torn out of the socket and expose electrical cores.



Cables from other devices used in the Cadence bed must not be pinched, crushed or pulled by the functions of the bed. Take appropriate precautions.

3. Safety instructions



If the mains supply cable or the mains plug is damaged, the complete supply cable with plug must be replaced. The work may only be carried out by the manufacturer or authorized specialists.



Do not use multiple sockets to connect the mains plug, as liquids can penetrate through them.
(Fire hazard and electrical shock)

Before cleaning and disinfecting the bed, the mains plug must be disconnected from the mains and securely hung up. The plugs for the handset and the motors which are plugged into the control unit on the lying surface drive must be plugged in. This is necessary so that no water can penetrate the control unit.



The maximum duty cycle and safe working load must not be exceeded, otherwise safe operation is no longer guaranteed (see technical data).

The Cadence beds must not be used in rooms where there is a risk of explosion.

The bed may only be dismantled if there is no patient or occupant in it.

3.2 Safety instructions for the operator



Use these operating instructions to instruct each user on safe operation before initial use.

Inform the user of any hazards that may exist if the device is not handled properly.

Only instructed persons may operate the bed. This also applies to persons who only operate the bed as representatives.

According to the Medical Devices Regulation (EU) 2017/745 and to the Medical Device Directive 93/42/EEC, beds are Class I active medical devices.



This results in obligations for you in accordance with the Medical Device Operator Ordinance (MPBetreibV) in order to ensure the permanently safe operation of this medical device without endangering patients, users and third parties. For long-term use of the systems, function checks and visible damage must be carried out and documented at least once a year (see chapter 9.2).

3.3 Safety instructions for the user

Let the operator instruct you in the safe operation of the Cadence bed.

In particular, observe the general safety instructions as described in para. 3.1.

Bed adjustments may only be carried out by instructed persons or in the presence of an instructed person.

Move the lying surface to the lowest position if you leave the nursing bed unattended with the patient. This reduces the risk of injury to the patient when getting in and out.

If malfunction or damage is suspected, immediately unplug the power cord from the outlet.

Mark the bed as a "defect" and take it out of operation. After that, please inform the responsible operator immediately.

3. Safety instructions

3.4 Cleaning and disinfection

Before cleaning and disinfection, the mains plug must be disconnected from the mains and securely hung up. The plug for the handset and the motors, which are plugged into the control at the lying surface drive, must be plugged in. This is necessary so that no water can penetrate the control unit.



Do not immerse the electrical components in water, but only wipe them off with a damp cloth.

The electrical components must not be sprayed with a high-pressure cleaner or water jet. Only wipe disinfection is permitted.



To avoid skin irritation, always wear liquid-impermeable gloves during cleaning and disinfection work.



Attention: When spray disinfecting with alcohol-containing agents, there is a risk of explosion and fire when used over large areas.



3.5 Maintenance and repair

Maintenance measures (inspection and maintenance) and maintenance (repair) may only be carried out by persons who have at least read the safety regulations, followed these operating instructions and are qualified in accordance with MPBetreibV (2021) §5.



Maintenance, inspection and repair work are not allowed to be carried out on the bed when it is in use and the patient is in it.



In order to detect possible defects in time and to ensure safe use, a technical check (visual and functional check) must be carried out by qualified personnel at least once a year according to the maintenance schedule (see chapter 9.2) after a longer period of inactivity and before each reuse.



If the tests reveal errors, damage or defects, the bed may no longer be operated. Maintenance of the Cadence bed must be carried out by qualified personnel in accordance with MPBetreibV (2021) §5.



Only original spare parts and accessories of the manufacturer may be used, otherwise all warranty and product responsibility are excluded





The 9V block battery is the energy storage device for electrical emergency lowering in the event of a power failure. The energy storage is sufficient for max. one emergency lowering and must then be replaced. If the expiry date of the batteries has exceeded, they must also be replaced immediately. As batteries are self-discharging, it is recommended to replace them every two years if they are not used. Make sure that this is an alkaline manganese battery of type 6LR61 and that only this type may be used. Empty batteries must be disposed of in an environmentally friendly manner.





3. Safety instructions

3.6 Accessories

 An erector is supplied as an accessory whose safe working load of 80 kg must not be exceeded. The trapeze bar is not used to lift persons, but makes it easier to change from a lying position to a sitting position or to change the position. The trapeze bar must not be swivelled outside the bed and must only be used within its permissible adjustment range, which is defined by the tube holder on the bed. Otherwise the bed may tip over completely and lead to serious injuries.

 Please only use mattresses that are compatible with the side rails supplied. The distance between the mattress surface in the non-compressed state and the upper edge of the upper side rail must be at least 22 cm. If the distance is less than this, a side guard must be used. As a rule, a mattress thickness of 12 cm is suitable.

 Make sure that the dimensions of the mattress match the dimensions of the lying surface of your Cadence bed. When using mattresses that are not compatible with this bed, hazards can arise, e.g. through falling out, trapping, etc.

 Another accessory for the Cadence beds is a bed extension that can be retrofitted and offers the option of increasing the bed length to 220cm or 230cm. Note the descriptions in Chapter 5.2.

The following accessories are also possible for the Cadence bed range:

- Side rail pad
- reading light
- Underbed lighting with motion detector
- Pluggable tablet
- wall deflection roller
- GPR

3.7 Storage

If the Cadence bed is to be stored for a longer period of time, the 9V block battery should be removed as a precaution to prevent damage to the bed from any leaking liquid.

3.8 Useful life and disposal

With correct operation and appropriate use, this bed has an expected service life of 7 to 10 years.



The bed must not be disposed of with normal household waste at the end of its service life. For environmentally friendly disposal, please contact your local authority or Harvest Healthcare.

The electrical components (power supply units, control units, drives and hand controls) of these beds are to be treated like electronic waste in accordance with WEEE Directive 2012/19/EU (Waste Electrical and Electronic Equipment) and disposed of properly.

The components used conform to the directive 2011/65/EU (RoHS II) on the restriction of the use of certain hazardous substances in electrical and electronic equipment.

 When disposing of it, please note that the bed or its accessories can be contaminated and contaminated with germs. Damage can also result in sharp edges, splintering, etc. These can lead to health risks.

4. Control of delivery and scope of delivery

On receipt of the delivery and before commissioning, check whether the nursing bed is damaged. Complain visible damage immediately to the delivering company.

After unpacking, please check that the delivery is complete. You will receive a fully assembled Cadence bed consisting of the following parts:



- a.** wooden headend
- b.** wooden footend
- c.** Electrically adjustable backrest
- d.** Electrically adjustable thigh support
- e.** Mechanically adjustable lower leg support
- f.** Hand switch with nurse key
- g.** Staff control panel (accessories)
- h.** Mechanical grid fitting for adjusting the lower leg support
- i.** Electric drive for backrest with slide-on power supply unit
- j.** Electric drive for thigh support
- k.** Mains cable with SMPS
- l.** Mattress guide
- m.** Wooden side rails (4 pieces)
- n.** Release button for side rail locking
- o.** Side rail guide
- p.** Mechanically adjustable castors
- q.** Central brake
- r.** Instruction for use

5. Assembly and commissioning

Note: The Cadence bed range is supplied fully assembled.

5.1 Assembly of Erector with triangle handle (accessory)

With the help of the erector, the patient can stand up and move more easily into another position. A triangle handle is attached to the erector.

Mount the erecting yoke by putting the two parts together (a) and screwing the star grip screw into the threaded hole (b) and tightening it! Insert it into the erecting fixture in the lying surface.

 Make sure that the locking cylinder pin (c) engages in the recess of the erecting fixture.

 Attention: The erecting bracket must not be used outside the latching mechanism.

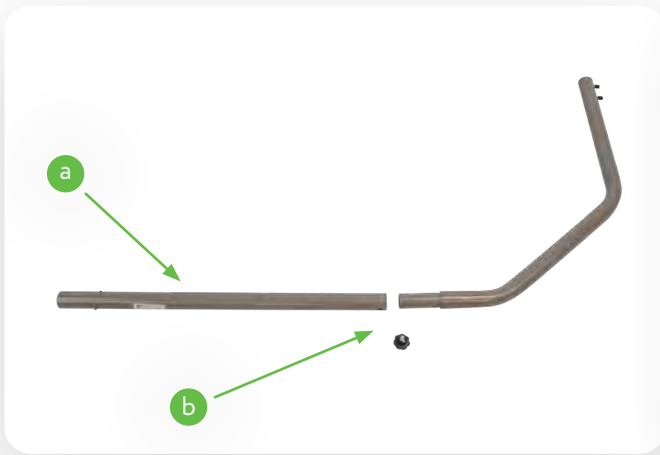

Slide the fixed loop of the triangle belt over the first bolt of the erector (a) and check that it is securely held by pulling the triangle handle downwards. Fix the loop of the triangle belt only between these two bolts.



The length of the strap of the triangle handle can be adjusted by the buckle. Select an adjustment that allows the user to easily reach the handle when lying down (usually between 55-70 cm measured from the upper edge of the mattress). Make sure that the belt is securely fastened again.

5. Assembly and commissioning

The triangle handle has a shelf life of at least 5 years under normal use (see embossing of production date). It is then recommended to replace the triangle handle.

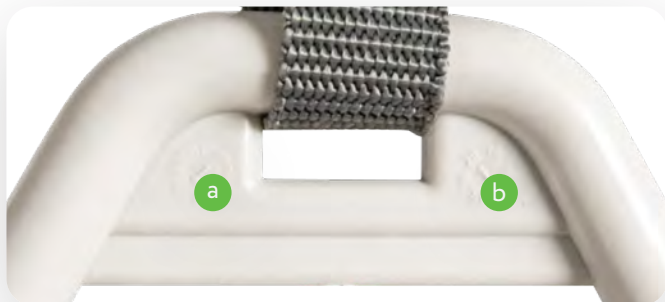

a. Production month

b. Production year

5.2 Mounting the bed extension (Accessories)

The Cadence beds offer the possibility of extending the lying surface up to 220 cm by means of the integrated bed extension, in order to be able to provide even larger patients with optimal lying comfort while maintaining the same functionality.

Note: If you want to extend the bed to 220 cm, you will need the following additional components to keep the bed in proper condition. These components must be purchased in advance.

When using continuous wooden side rails			
No.	Component	Article number	Unit
1	Bed extension (bed extension, pull catch/cable, fastening material)	BC 9.04.0655340	Set
2	Extended side rails (4 side rail bars) if undivided side rails were previously used	276	piece
3	Side rail end caps	BC 4.03.1990000	Set
4	20cm or 30cm mattress extension (1 piece) or one mattress 90 x 220/230cm		piece
5	If visually desired, extended side panels (2 pieces) for the bed extension	HO-SBL-01-PFR5320 -PFR5320 = beech	Set

When using split side rails			
No.	Component	Article number	Unit
1	Bed extension (bed extension, Pull catch/cable, fastening material)	BC 9.04.0655340	Set
2	20cm or 30cm mattress extension (1 piece) or one mattress 90x220/230cm		piece
3	Protector	BC 9.04.0653380	piece

5. Assembly and commissioning

Follow the assembly instructions below when using the bed extension:



The bed extension must not be used as a seat!



The patient must not be in the bed while the bed extender is being set up.

1. Remove the mattress from the bed.
2. Dismantle the side rails. To do this, unscrew the socket screws **(a)** at the bottom of the foot section and pull the support block out of the side rail. For this dismantling step, the side rail bars should first be pulled up and locked in place.
3. Press the side rail lock release button **(b)** on one side and carefully lower the side rails until they have slid completely out of the guide rails. Keep the side rail stiles for possible dismantling.



4. Loosen the two hexagon socket screws **(c)** underneath the lying surface frame on the foot side.
5. Pull the foot section out of the lying surface frame **(d)**.

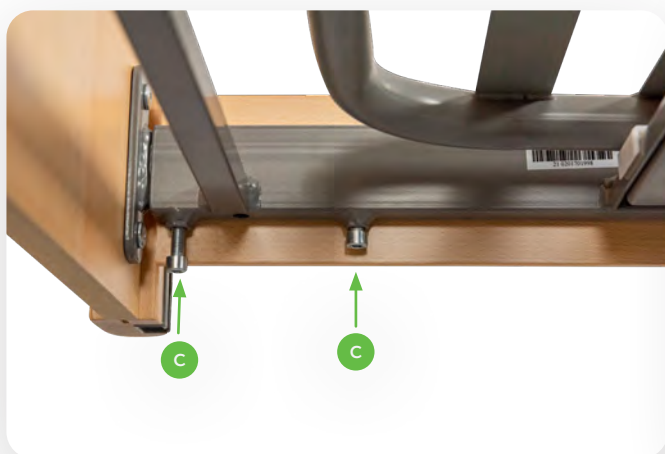

5. Assembly and commissioning

6. Dismantle the existing brackets (e) on the foot section plate.

7. Place the bed extension (f) on the drill holes (g) of the previously dismantled angles of the foot section and screw them tight with the 4 screws.

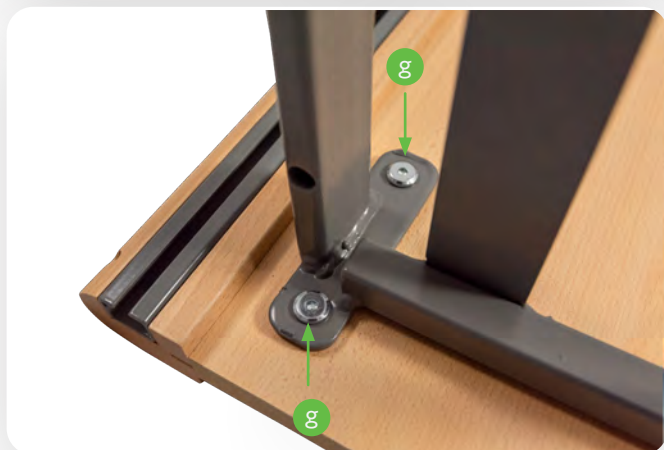
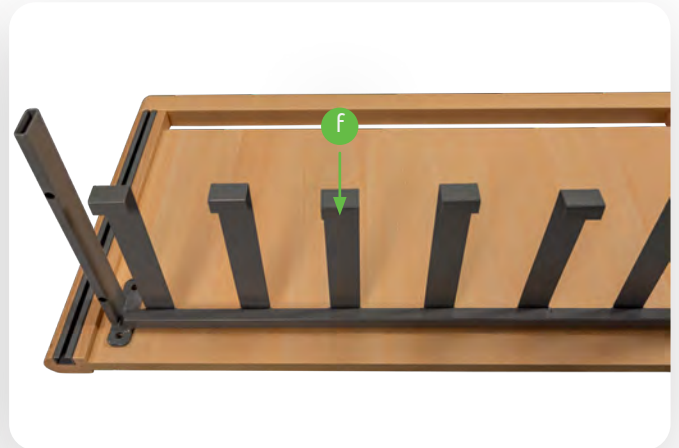

8. Insert the foot section incl. the bed extension into the openings of the lying surface frame (h). The hooks (i) of the bed extension must engage in the last cross strut of the lying surface frame.

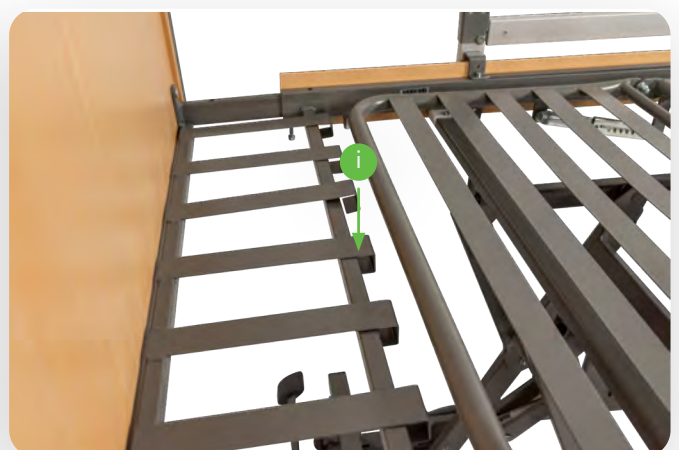

5. Assembly and commissioning

9. Screw the two detent bolts (j) with the cable into the threaded mounts (k) attached to the frame and tighten them hand-tight with an open-end wrench.



10. If you need the undivided wooden side rails, the extended side rails must now be fitted. To do this, go through steps 2 to 3 in reverse order.

-  11. If you use the 2-part split aluminium side rails or the 3-part split steel side rails, you must attach the optionally available pro-protector to the bed extension on both sides.

5.3 Protector (Accessories)

-  **When using the bed extension and the split side rails, it is necessary to retrofit the protector to prevent the patient from getting trapped or falling out. The openings between the split side rails and the footboard of the bed must be either less than 60 mm or at least 318 mm.**

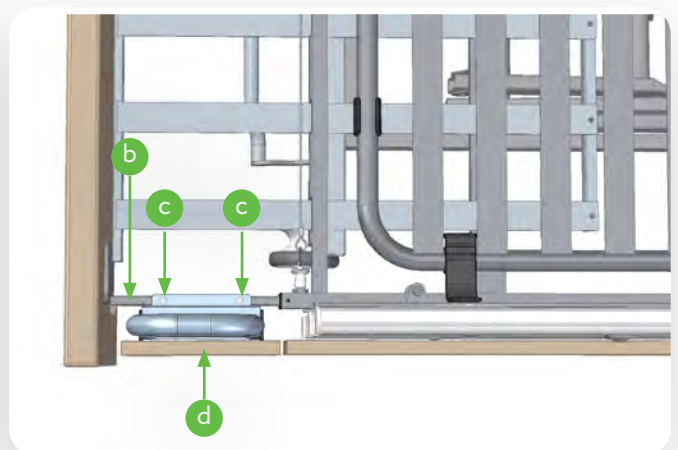

1. Position the protector (a) on the bed extension frame (b).
2. Attach the protector to the frame with the two screws (c) provided.
3. Screw the side panel extension (d) onto the protector from the inside.

5. Assembly and commissioning

5.4 Assembly of the 2-part split aluminium side rails (Accessories)

When installing the 2-part split aluminium side rails, proceed as follows:

1. Before mounting the aluminium side rails on the Cadence bed frame, the wooden side panels **(a)** must be attached to the side rails **(b)**.
2. Place the rubber spacer **(c)** between the wooden side panel and the side rail and guide both screws **(d)** through the holes in the side rail, spacer and wooden side panel.
3. Tighten both screws.
4. Also mount the wooden side panels on the other aluminium side rails.

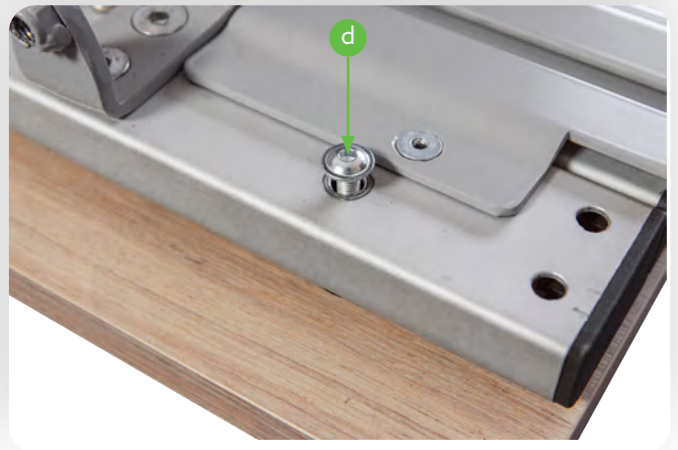
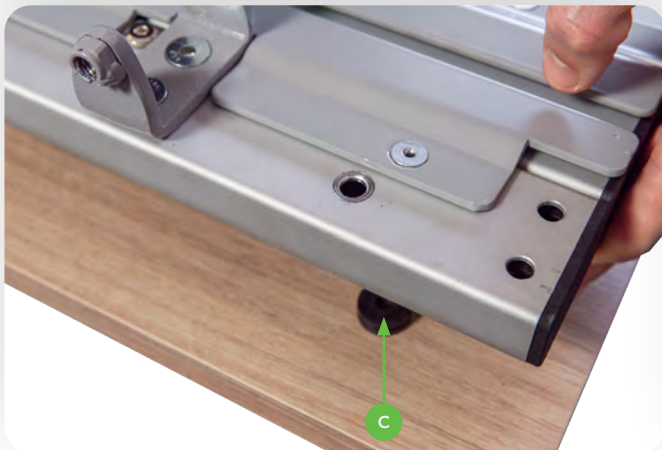
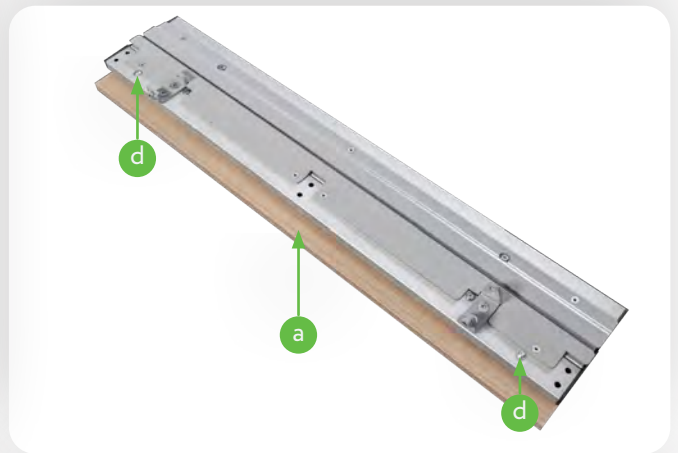

5. Position the side rails on the long side of the Cadence bed frame in such a way that the rectangular fastening tab **(e)** points towards the head end of the bed and is flush with the first hole **(f)** in the lying surface frame.
6. Push the Allen cylinder head screw **(g)** through the holes and fasten it with a threaded nut.

5. Assembly and commissioning

7. The rear rounded fastening strap (**h**) must be pushed over the profile of the lying surface frame.

8. Secure the rear mounting bracket with the Allen cylinder head screw (**i**) and the threaded nut.

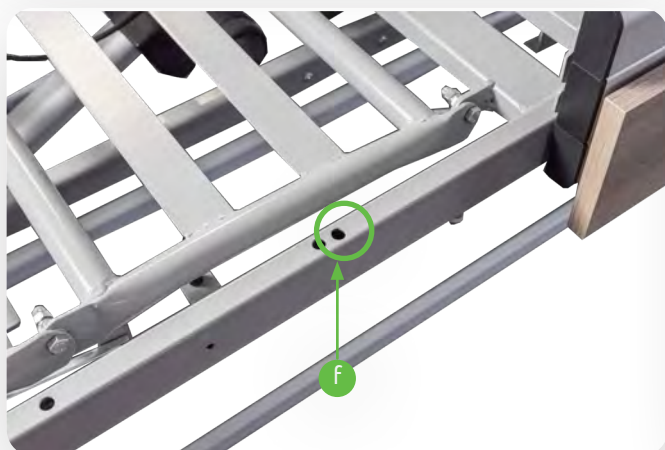

5. Assembly and commissioning

5.5 Assembly of the 3-part split steel side rails (Accessories)

When installing the 3-part split steel side rails, proceed as follows:

1. Position the large side rail element **(a)** on the long side of the Cadence bed frame so that the two fastening straps **(d)** are flush with the holes in the lying surface frame.
2. Insert both Allen socket head screws **(e)** through the holes in the mounting brackets and the bed frame profile.
3. Connect both cylinder head screws with a threaded nut **(f)** and tighten them.
4. Follow the same sequence of steps to assemble the two smaller side rail elements and the three side-rail elements on the opposite side of the Cadence bed.

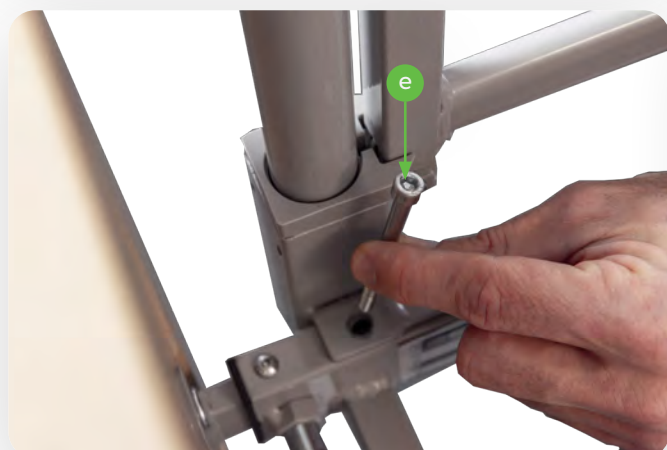
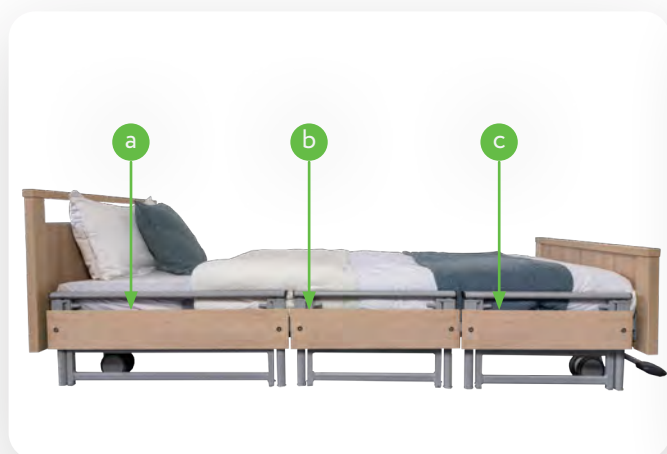

5. Assembly and commissioning

5. Finally, you must attach the wooden side panels **(g)** to the six side rail elements by screwing them to the outside of the side rail elements with the Allen cylinder head screw **(h)**.

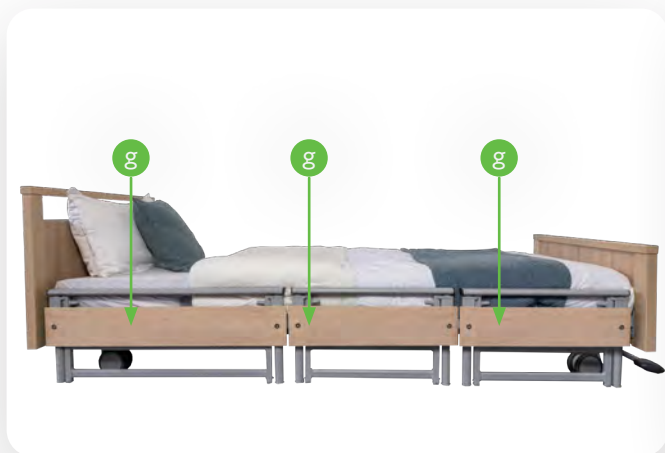

5. Assembly and commissioning

5.6 Commissioning

Connecting the nursing bed to the mains socket.
Insert the mains plug into the socket.

The mains plug should always be accessible so that in an emergency the system can be disconnected from the mains supply by pulling it out of the socket. The electric actuators are now ready for operation.



The Cadence bed range is ready for operation after it has been successfully installed and all the steps in Chapter 5, Paragraphs 5.1 and 5.5 have been followed.

Once the Cadence profiling bed has been installed, carry out a check in accordance with Chapter 9, Paragraphs 9.2.

Clean and disinfect the bed before using it for the first time and before each use according to chapter 7.

6. Functional description

6.1 Technical overview

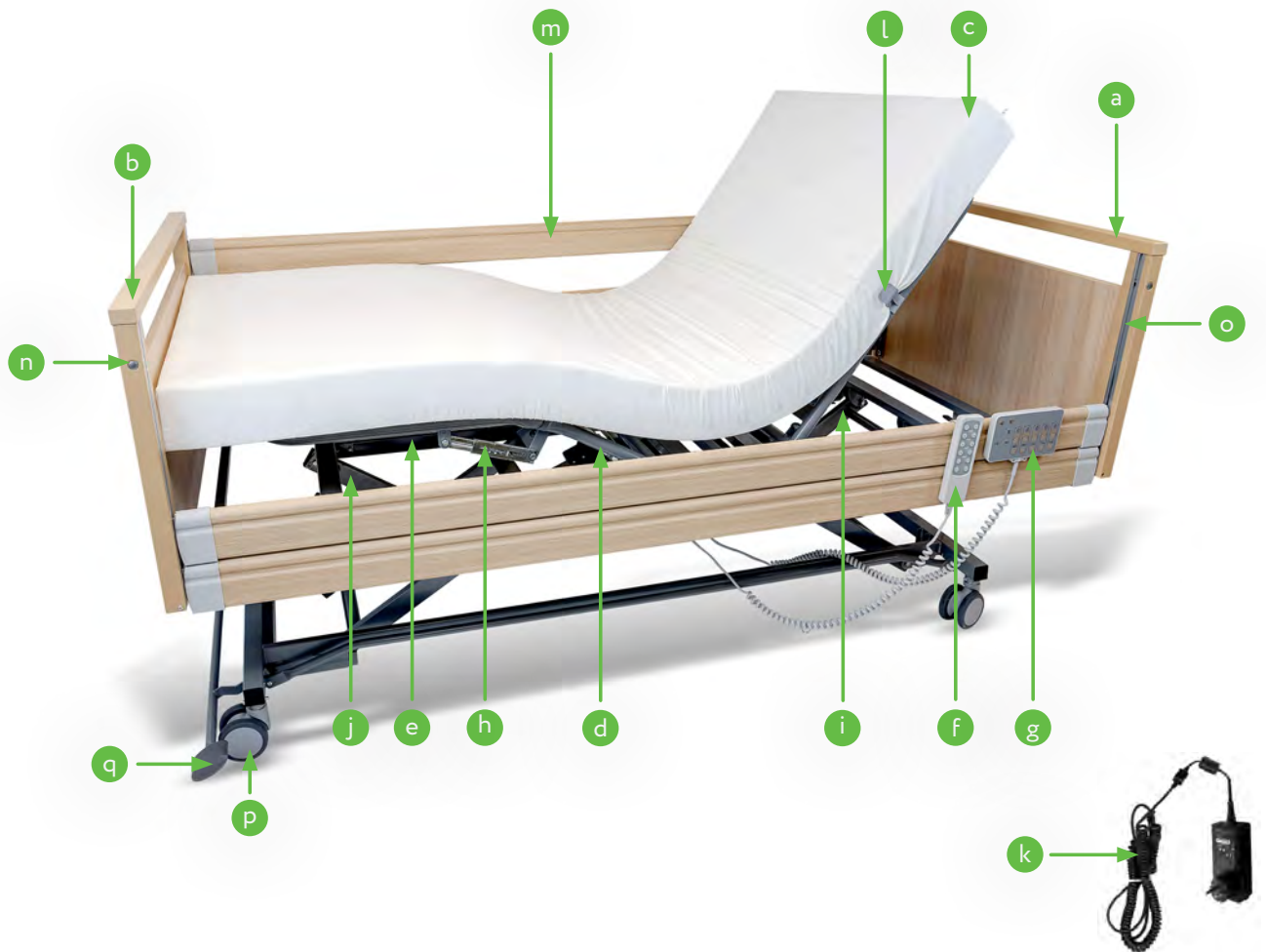

- a.** wooden headend
- b.** wooden footend
- c.** Electrically adjustable backrest
- d.** Electrically adjustable thigh support
- e.** Mechanically adjustable lower leg support
- f.** Hand switch with nurse key
- g.** Staff control panel (accessories)
- h.** Mechanical grid fitting for adjusting the lower leg support
- i.** Electric drive for backrest with slide-on power supply unit
- j.** Electric drive for thigh support
- k.** Mains cable with SMPS
- l.** Mattress guide
- m.** Wooden side rails (4 pieces)
- n.** Release button for side rail locking
- o.** Side rail guide
- p.** Mechanically adjustable castors
- q.** Central brake

6. Functional description

6.2 Handset with locking function

The bed electric functions can be operated via the handset. All functions can be locked with the nurse key.

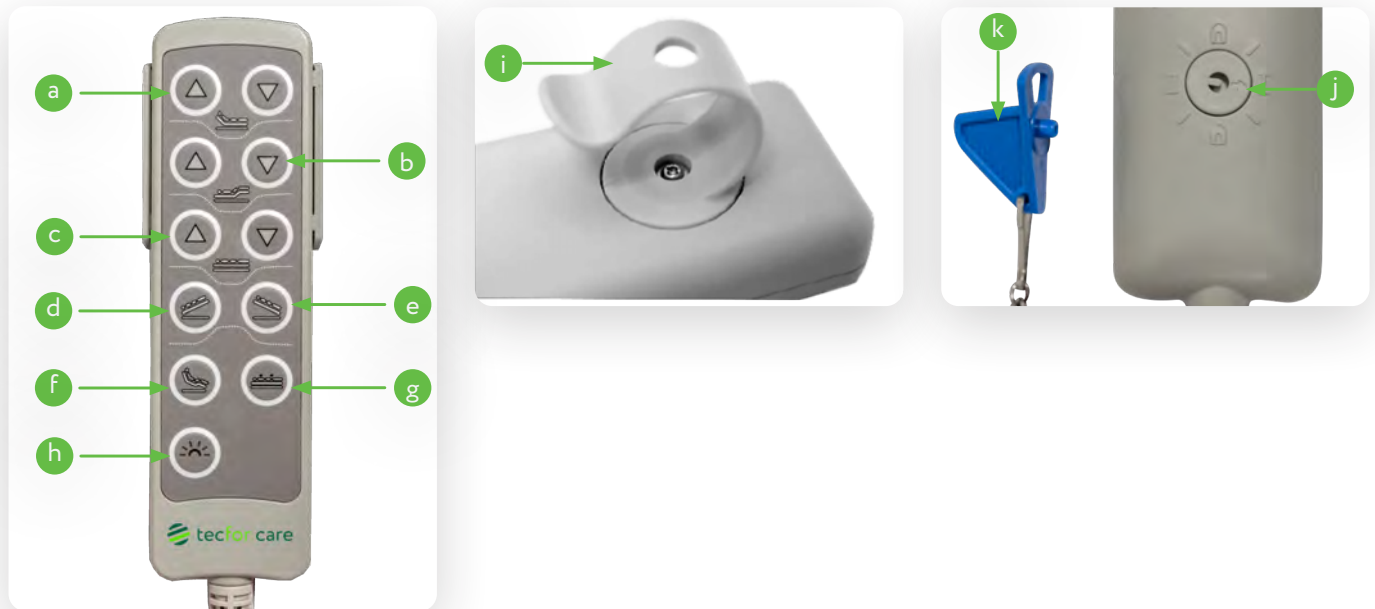

- a.** Backrest adjustment up/down electric stepless variable 0°-70°
- b.** Thigh adjustment up/down electric stepless variable 0°-30°
- c.** Lying surface up/down electric stepless 380-800 mm
- d.** Trendelenburg position electrically stepless with separate locking function
- e.** Anti-Trendelenburg position electrically stepless with separate locking function
- f.** Comfort seating position, back adjustment, thigh adjustment and total lying surface. Head-up at the push of a but-ton
- g.** Height adjustment
- h.** Key illumination
- i.** Hand switch hook
- j.** Lock for activating/deactivating the handset functions
- k.** Nurse key

To avoid damage, the hand control should always be suspended from the hand control hook when not in use (e.g. lying surface frame or side rails).

Do not press multiple keys at the same time as this may overload and damage the system.



6. Functional description

6.3 Locking function for handset

There is a lock on the back of the hand control. All electrical adjustment functions can be locked simultaneously by turning the enclosed nurse key in the lock



Blocking function 1: 
functions are locked.



Blocking function 2: 
Trendelenburg + low position are blocked. All other functions are enabled.



All functions are enabled. (I)



All functions are enabled. (II)

6. Functional description

6.4 Operation of the side rails

6.4.1 The continuous side rail

1. To use the side rails, lift the upper side rail **(a)** until it engages in the highest position.
2. To lower the side rail **(a)**, lift the upper side rail and simultaneously press the release button **(b)** for the side rail lock and release the side rail.

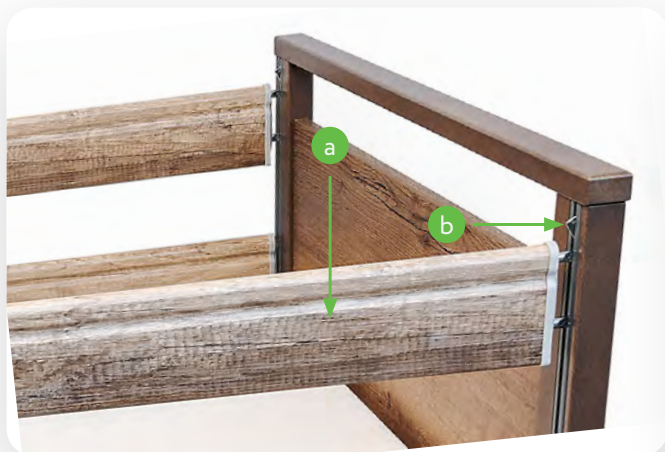

When the side rail is raised, always ensure that it is securely engaged!

The side rails are only intended to prevent people from falling out of bed. Do not climb or lean over them under any circumstances!

Use the following overview to check the use of the correct side rail and the permissible positions or distances of the side rail variants.

Continuous side rail, divided in two with 95mm wide uprights.

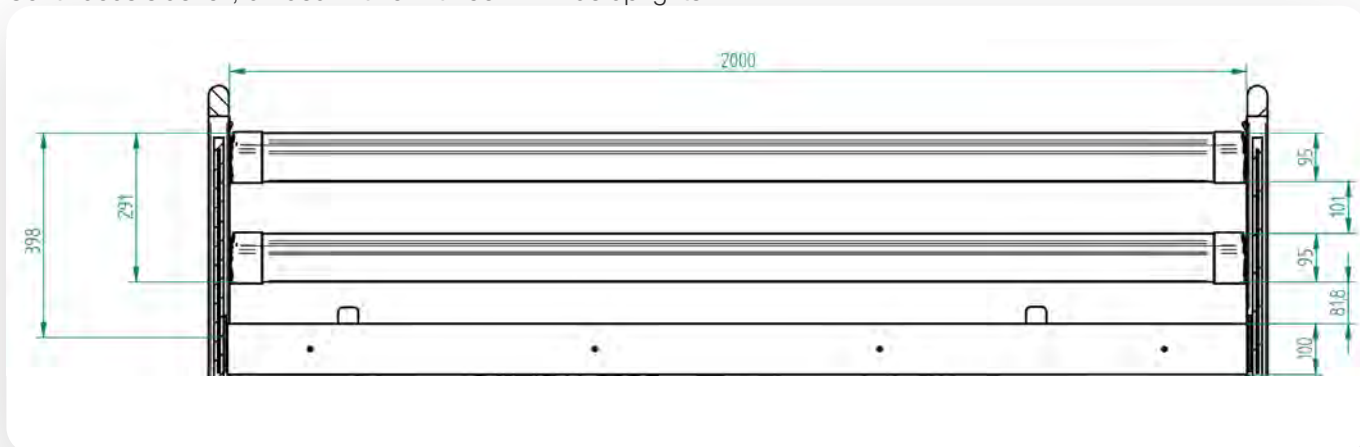

6. Functional description

Continuous side rail, divided in two with 115mm wide uprights.

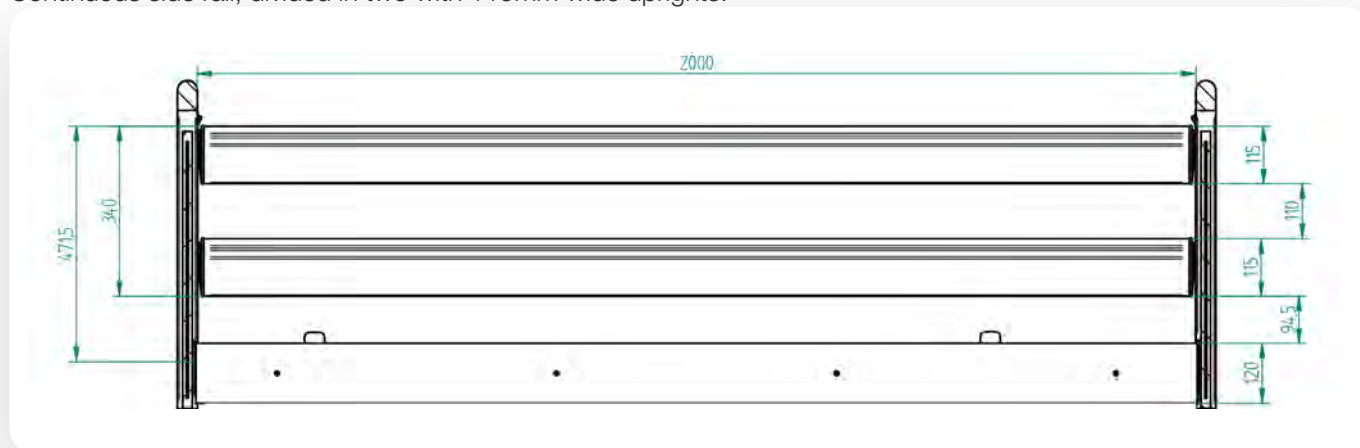

6.4.2 The 2-part split Aluminium side rails

1. To use the 2-part split side rails, pull the upper side rail element (a) upwards until you hear it click into place.
2. To lower the side rail, lift the upper side rail element and then press both release buttons (b) for the side rail lock at the same time. Lower the side rail.



 Use the following overview to check the use of the correct side rail and the permissible positions or distances of the side rail variants.

2-part split aluminium side rails (1 set/ 2 pieces)

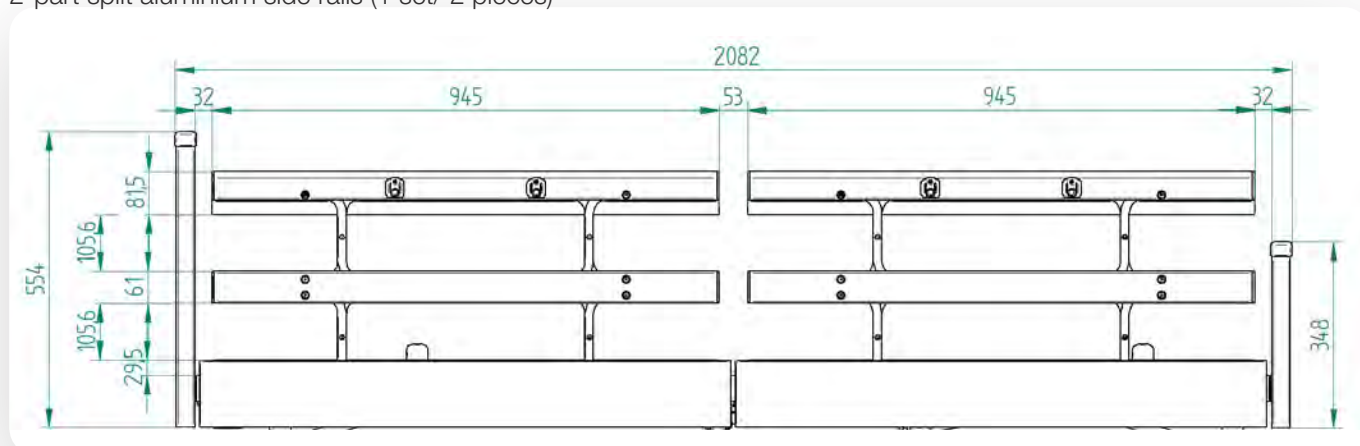

6. Functional description

6.4.3 The 3-part split steel side rail

1. To use the 3-part split side rails, pull the upper side rail element **(a)** upwards until you hear it click into place.
2. To lower the side rail, lift the upper side rail element and then pull both release buttons **(b)** for the side rail lock at the same time. Lower the side rail.

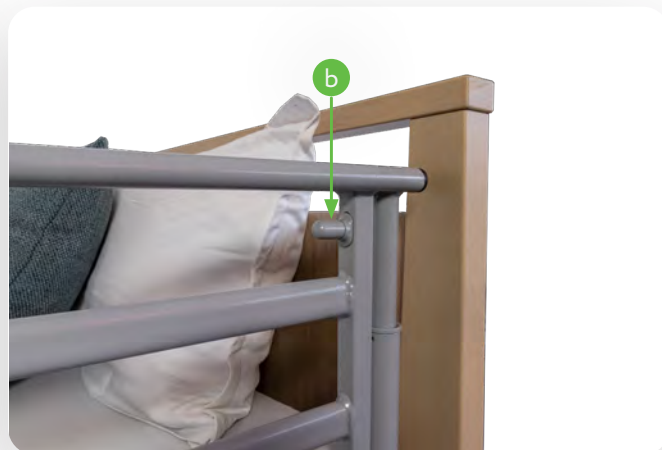
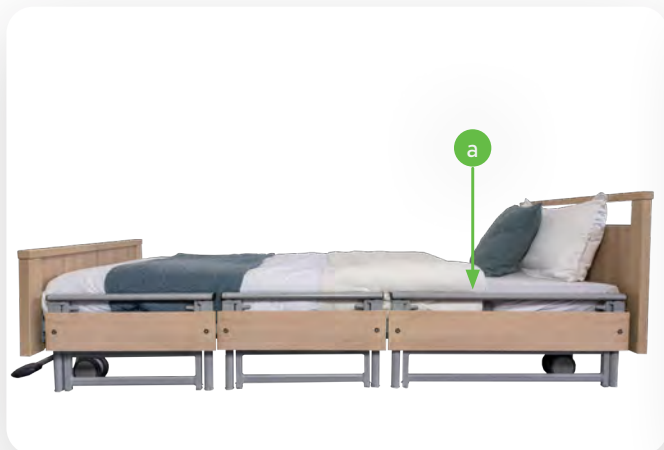

Use the following overview to check that you are using the correct side rail and the permitted positions and spacing of the side rail variants.



3-part split side rails (1 set / 3 pieces)

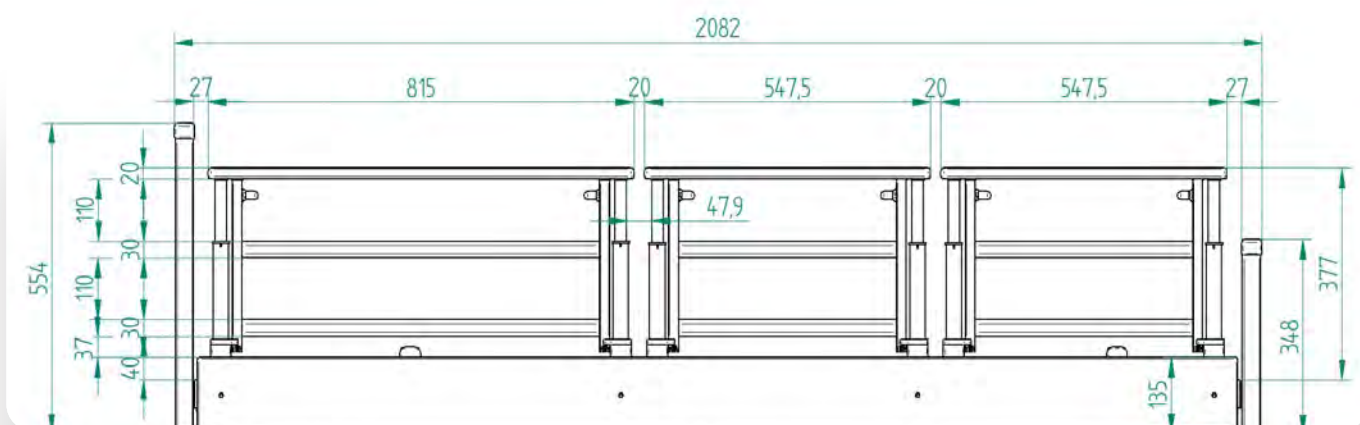

6. Functional description

6.5 Operation of the bed extension

Thanks to the bed extension, the Cadence profiling bed can be adjusted flexibly, without tools, to different bed lengths. The normative requirements of IEC 60601-2-52 are complied with in every position of the bed extension.

1. To use the bed extension, pull up the wire rope at the foot end **(a)** and pull out the bed extension **(b)**.
2. Let go of the wire rope and pull out the bed extension until both detent bolt **(c)** are fully engaged in the holes.

 The bed extension can be extended up to 220cm **(d)** or up to 230cm **(e)**.
When extending the bed to 220cm, it is absolutely necessary to fit the foot-side protector **(f)**.

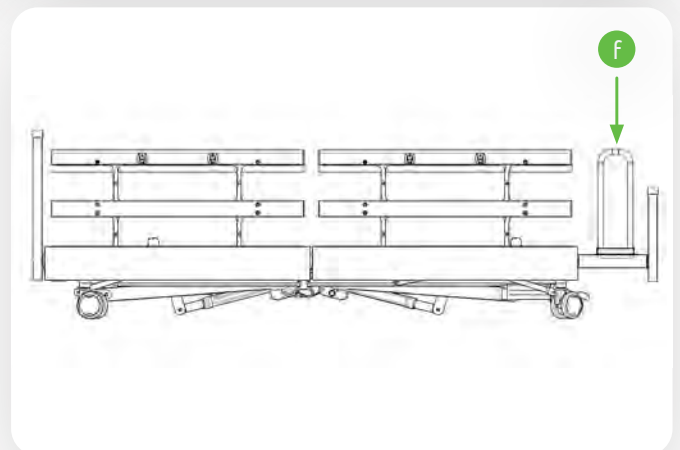
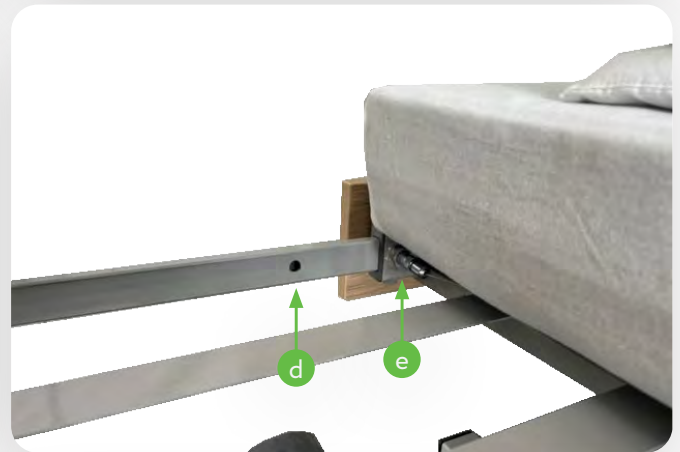

6. Functional description

6.6 Operating the central brake

All the rollers of the bed can be locked via a central braking device by means of a brake bracket at the foot end of the bed and must always be locked during normal operation.



Press the brake lever downwards until it engages
(a) the 4 rollers are locked.



Raise the brake lever: **(b)**
the 4 rollers are released.

Release the brake only when moving the Cadence bed. See also safety instructions.

It is not permitted to stand with the entire body weight on the foot bar of the central brake.



6.7 Emergency lowering

6.7.1 Emergency lowering via integrated 9V battery (electric)

The control unit mounted on the lying surface is equipped with a 9V block battery, which enables the individual electrical adjustment functions to be lowered in the event of a mains power failure. If the mains power should fail, you have the option of returning the electric drives to their lowest position. Please note that this is only possible once per 9V battery, as the capacity of the 9V battery is very limited.



After using the emergency lowering once, the 9V block battery must be replaced with a new equivalent one. (Alkaline manganese battery type 6LR61)

However, the 9V block battery should be replaced every 2 years even if not in use.

6.7.2 Battery change

To replace, check or remove the 9V battery for longer storage, the battery must be removed from the battery compartment of the control unit, which is installed under the lying surface.

Replace the battery as follows:

- Disconnect the mains plug.
- Unscrew the central Allen screw **(a)** from the battery compartment.
- Take out the battery compartment along with the two 9V batteries **(b)**.
- Disconnect the batteries from the battery clip **(c)**.
- Replace the batteries with new equivalent batteries of the type „alkaline manganese battery type 6LR61“.

6. Functional description

- Position the battery compartment back onto the battery compartment bracket on the frame (**d**) and tighten the socket head screw.

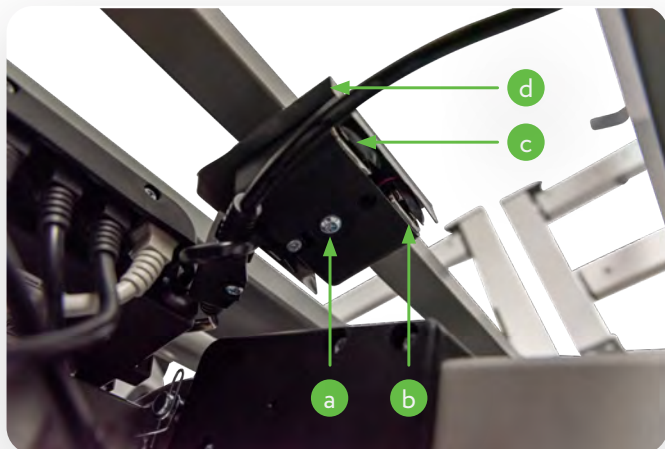

6.7.3 Emergency lowering of the backrest (manual)

If the backrest has to be lowered in less than 30 seconds in the event of a power failure or the electric drive system of the nursing bed has failed, you can lower the backrest manually.

 Observe these safety and implementation instructions, as non-compliance can lead to uncontrolled falls from the backrest and thus to serious injuries for the user and the patient!

 Always carry out the emergency lowering of the backrest by hand with two users!

 Manual emergency lowering may only be carried out by instructed users and should be practised several times under normal conditions in order to be able to lower the backrest safely in an emergency.

Execution of mechanical emergency lowering:

- The first user relieves the backrest before the emergency lowering by lifting the frame and holding it in this position. If necessary, the second user supports this process.
- The second user folds the bent safety clip (**a**) of the pin at the end of the backrest lift motor.
- Then he pulls the socket pin (**b**) out of the lifting rod (**c**). The lift motor is now separated from the backrest and swivels downwards.
- Both users lower the backrest slowly and in a controlled manner.

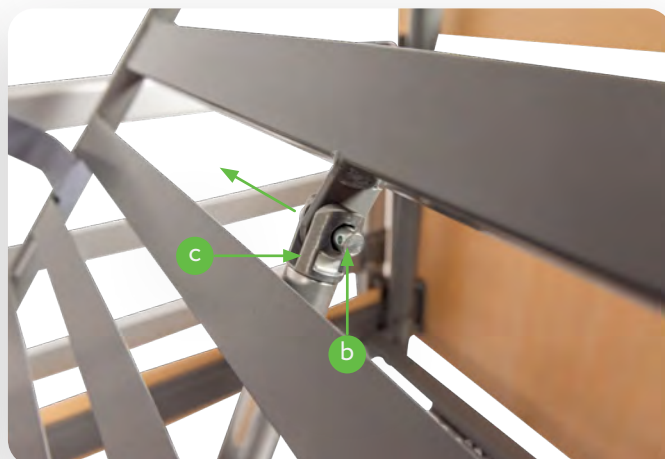

6. Functional description

Restoration of the original condition:

- Swivel the lift rod of the lift motor up again in the direction of the backrest.
- Insert the socket pin into the mounting of the lifting rod and the Cadence bed frame.
- Make sure to reinsert the socket pin from the operator side so that it is accessible at all times.
- Close the safety clip on the socket pin.

6.7.4 Trendelenburg / Antitrendelenburg function (option)

Optionally, the Trendelenburg positioning function **(a)** or Anti-Trendelenburg positioning function **(b)** is available for the Cadence profiling bed.

In Trendelenburg positioning, the lying surface of the nursing bed is inclined towards the head.

In the case of Anti-Trendelenburg positioning, the support surface is inclined towards the feet.



Trendelenburg positioning may only be used at the instigation of a doctor, as it can have an effect on the clinical condition of the patient.



Do not leave the patient unattended during Trendelenburg or anti-Trendelenburg positioning.



Locking function on the hand switch for the Trendelenburg / Anti-Trendelenburg function: If the bed is optionally equipped with the Trendelenburg / Anti-Trendelenburg function, this function can be locked separately, i.e. independently of the locking function **(c)** of the general adjustment functions (see Chapters 6.2 and 6.3) on the back of the hand control with the nurse's key 



Lock the Trendelenburg function when using the bed in application environment 4 (home care).



6. Functional description

6.7.5 Comfort seating position

The comfort seating position enables the patient to adopt a comfortable seated position, e.g. when watching television. In the comfort seating position, the back section and thigh section are raised at the same time and the entire lying surface moves into the head-elevated position.

To set the comfort seat position, button **(a)** on the handset must be pressed until the desired position is reached.

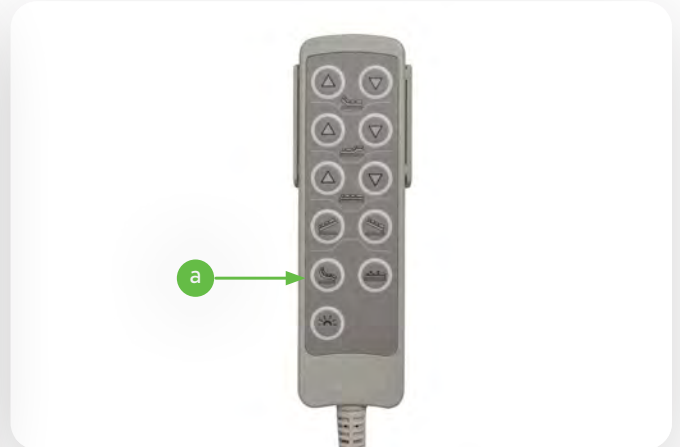

6.7.6 Lowest position

The lowest position enables the lying surface to be lowered electrically to 240 mm.. The lowering of the lying surface close to the ground is used, for example, specifically to prevent falls.

To set the low position, button **(b)** on the handset must be pressed until the desired position is reached.

There is a lock **(c)** on the back of the handset to lock the setting of the lying surface in the low position. Set the padlock to lock function 2 

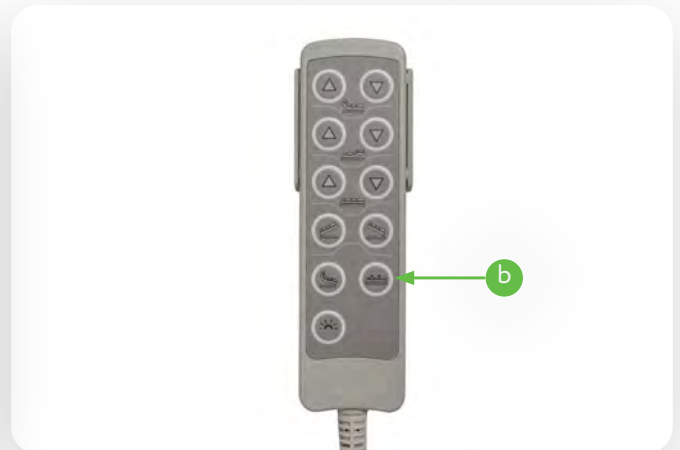

6. Functional description

6.7.7 Staff control panel (accessories)

The adjustment functions of the back section, the thigh section, the Trendelenburg and Anti-Trendelenburg function and the lying surface height can be individually operated or locked with the staff control panel. These blocks are transferred to the associated adjustment functions of all handsets connected to the bed by cable. All connected handsets can also be completely blocked via the staff control panel.

The staff control panel is directly connected to the control box.

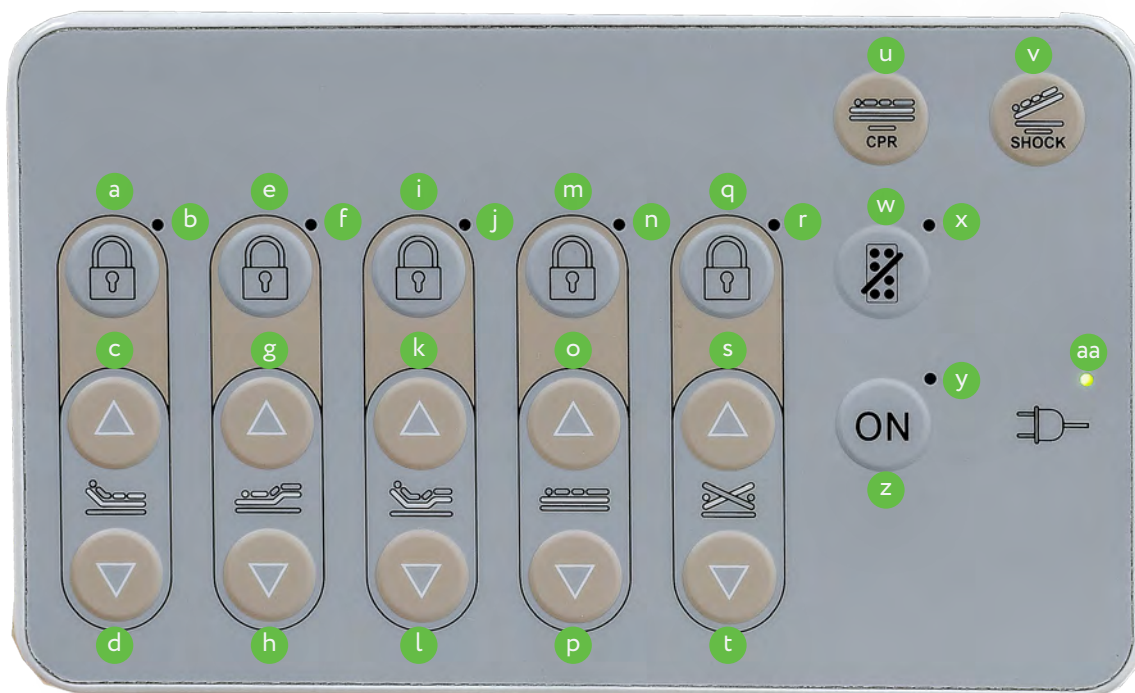

- | | | |
|---|--|--------------------------------------|
| a. Lock backrest function | l. comfort lying position down | w. Lock patient handset |
| b. LED lock backrest | m. Lock height adjustment | x. LED Lock patient handset |
| c. backrest up | n. LED Lock height adjustment | y. LED staff control panel on |
| d. backrest down | o. height adjustment up | z. staff control panel on |
| e. Lock thigh section | p. height adjustment down | aa. LED mains supply |
| f. LED Lock thigh section | q. Lock Trendelenburg / Anti-Trendelenburg function | |
| g. thigh section up | r. LED Lock Trendelenburg / Anti-Trendelenburg | |
| h. thigh section down | s. Anti-Trendelenburgfunction | |
| i. Lock comfort lying position | t. Trendelenburgfunction | |
| j. LED Lock comfort lying position | u. electric emergency lowering | |
| k. comfort lying position up | v. shock storage | |

7. Care, cleaning and disinfection

Clean and disinfect the Cadence bed before first use and before each reuse. The bed should be wiped by hand with a damp cloth for cleaning. We recommend suitable cleaning and care products as cleaning agents for wooden and plastic furniture.

Household cleaners that are free from ammonia and abrasives are also permitted, but should be dermatologically tested. Solvents and abrasives are not permitted as they attack and damage the various surfaces of the bed.

For disinfection:

Note: In order to achieve effective disinfection, the nursing bed must be cleaned beforehand. Disinfection is possible by spray or wipe methods with commercially available disinfectants. Do not use disinfectants containing chlorine as they can have a corrosive effect on metals, plastics etc. and are not environmentally friendly.

For wipe disinfection (surface disinfection) we recommend approved disinfectants and disinfection procedures from the list of disinfectants and disinfection procedures tested and approved by the Robert Koch Institute (<https://www.rki.de>) or from the VAH disinfectant list (Verbund für Angewandte Hygiene e.V. / <https://vah-online.de>).



Before cleaning and disinfection, the mains plug must be disconnected from the mains and securely suspended. The plugs for the handset and the motors which are plugged into the control unit on the lying surface drive must be plugged in. This is necessary so that no water can penetrate into the control unit.



The electrical components must not be sprayed with a high-pressure cleaner or water jet. Only wipe disinfection is permitted.

8. Cause and remedy of malfunctions

Not every malfunction is directly attributable to a defect in the nursing bed. Before contacting Harvest Healthcare, please check the malfunction using the table below.

Malfunction	Possible cause	Remedy
No function	Mains plug not plugged in	Plug in the mains plug.
	Lock function on handset activated	Unlock the handset.
	Handset not plugged in	Insert the handset into the control unit.
	Drive not plugged in	Plug the drive into the control unit.
Reversed adjustment functions	connection cables on the sockets reversed	Check plugs and sockets and reconnect.
No function after power failure	9V block battery is empty	Replace 9V block battery.
Bed moves very slowly	Bed can only be adjusted via battery; mains plug not plugged in	Plug in the mains plug and replace the 9V block battery preventively.

9. Maintenance

9.1 Basics

In accordance with MPBetreibV §7 (as of 2021), operators of profiling beds are obliged to ensure the safe and proper operation of the medical device on an ongoing basis by means of maintenance measures (inspection and maintenance). The service life of the Cadence bed depends essentially on handling and maintenance. To ensure safe operation, we recommend that a visual and functional check, including an electrical check, be carried out at least once a year and before each reuse as a guide value, under your own responsibility and with verifiable compliance with the 2% error rate (see also DGUV regulation 3 §5, table 1B). If an error rate of <2% is demonstrably achieved during the electrical test, the test cycle can be extended to a maximum of two years.

Carry out maintenance at least once a year and before each reuse according to the maintenance schedule and the test regulations according to IEC 62353 in its current version.

The following tests according to IEC 62353 apply to our beds:

1. Visual inspection
2. Leakage current measurement
3. Insulation resistance measurement
4. Functional test
5. Overall assessment and documentation

 If you have any doubts about the safety or function of even a part of the bed during the maintenance measures described below, the bed must never be put back into operation. Then contact the supplier or manufacturer.

 Maintenance, inspection and repair work are not allowed to be carried out on the nursing bed when it is in use and the patient is in it.

 Electrical components must not be opened and must be replaced as a whole. Defective electrical components must be replaced by qualified personnel.

 The electrical tests described here in accordance with IEC 62353 may only be carried out by a qualified electrician or, if suitable measuring and testing equipment is used, by a person trained in electrical engineering. .

9. Maintenance

9.2 Maintenance schedule

Bed Type ○ Cadence with undivided wooden side rails ○ Cadence with 2-part split Aluminium side rails ○ Cadence with 3-part split steel side rails
 Serial No.: Responsible:
 Location: Inspector:

Pos.	Test instruction	OK	Not OK	Comment
1.	Examination of the basic prerequisite			
1.1	Is the general condition okay?			
1.2	Type plate from the nursing bed and the electrical components, legible?			
1.3	Instructions for use available and accessible to personnel?			
1.4	Appropriate and safe use?			
2.	Visual inspection			
2.1	No surface damage or corrosion?			
2.2	Mechanical components and welds without defects?			
2.3	All mechanical connecting elements are fixed?			
2.4	Lying surface floor without damage?			
2.5	Firm fit and no damage to the head and foot end pieces?			
2.6	All 4 rollers undamaged and fixed?			
2.7	Parking brakes are undamaged and fixed?			
2.8	Side rails without break, crack or other damage?			
2.9	Fixed seat of the side rails in their fastening?			
2.10	Erector with grab handle and erector holder undamaged and no wear?			
2.11	Mains cable, connecting cables and plugs without damage?			
2.12	Transport protection for mains plug available?			
2.13	Strain relief for mains cable and handset securely fastened?			
2.14	All plug connections are firmly plugged in? (sealing rings without damage)			
2.15	Correct and safe cable laying? (no damage)			
2.16	Motor, SMPS power supply and mains plug housings without damage?			
2.17	Handset without damage?			
2.18	Thrust tubes of the height adjustment drives are undamaged?			
2.19	Socket pin with safety bracket on backrest drive is freely accessible for mechanical emergency lowering?			
2.20	9V block battery OK / expiration date sufficient until next test?			
2.21	Is the safe working load maintained?			
3.	Electrical test according to IEC 62353			
3.1	Insulation resistance >7MΩ? / measured value:			
3.2	Device leakage current <0.5mA? / Measured value: The measurement of the device leakage current does not have to be carried out in the normal life expectancy of the bed (within the first 10 years) if the visual and functional test has been passed if these beds are equipped with a drive set from the manufacturer limoss and a power supply unit (SMPS) from the manufacturer limoss. With these beds, the incoming mains voltage is converted into a protective low voltage of 29V in the power supply unit (SMPS).			

9. Maintenance

4.	Functional test			
4.1	All adjustment possibilities of the nursing bed without obstacles on site?			
4.2	Does the locking mechanism for lower leg adjustment work?			
4.3	Stress test successfully carried out according to regulations?			
4.4	Function test of the handset: correct operation of the keys?			
4.5	Function test of the handset locking device: On/Off OK?			
4.6	Check of the first-error safety by means of an integrated locking box in the handset without complaint?			
4.7	Function of the side rails, secure engagement?			
4.8	Side rails run smoothly in their guide rails			
4.9	Max. Distance between the side rails 12 cm?			
4.10	Side rail height above the mattress at least 22 cm?			
4.11	Track rollers, easily rotatable by 360°?			
4.12	central brake are functional (sufficient braking effect available)?			

Overall rating Overall assessment of the Cadence bed in order?

Remarks:

Place / Date: Inspector:

Next test: Signature:

9. Maintenance

9.3 Check of single-fault safety by means of the integrated locking function in the handset

Proceed as follows to check the safety device:

The switching positions I and II are test settings which are only used for safety checks as part of the annual inspection or after repair or before each re-use of the bed.

1. Move the lock to switching position I or II: First move all bed adjustments to a slightly raised position.
2. Set the switch positions to test position Locking function 1 or 2 (I): No electrical adjustments must be possible when the adjustment keys on the handset are pressed.



Blocking function 1:Functional test 1



Blocking function 1:Functional test 2



Blocking function 2: Functional test 1



Blocking function 2: Functional test 2

10. Warranty

Within the scope of our terms of delivery and payment, we guarantee the perfect condition of our beds. In the event of unauthorised modifications to the product, improperly carried out maintenance work and use contrary to the instructions for use, warranty and product liability claims shall lapse.

11. Useful life and disposal

The service life naturally depends on the way in which the bed is used. With correct operation and appropriate use, this Cadence bed has an expected service life of 7 to 10 years.

The Cadence profiling beds are suitable for re-use in accordance with the measures in chapters 7 and 9. Frequent transport, installation and adjustment reduce the service life, as do improper handling, irregular maintenance and exceeding the safe working load or permissible load cycles of the electric drives. The bed must not be disposed of with normal household waste at the end of its service life. For environmentally friendly disposal, please contact your local authority or Harvest Healthcare Ltd.

The electrical components (power supply units, control units, drives and hand controls) of these beds are to be treated like electronic waste in accordance with WEEE Directive 2012/19/EU (Waste Electrical and Electronic Equipment) and disposed of properly.

The components used conform to the directive 2011/65/EU (RoHS II) on the restriction of the use of certain hazardous substances in electrical and electronic equipment.



12. Technical specifications

12.1 Technical data (mechanical)

Safe working load (max. permissible load)	235kg	
Individual loads of the safe working load	20kg	
Accessories (erector)	15kg	
Max. patient weight	200kg	
Mattress dimensions	200x90x12cm	
Max. height	80cm	
Continuous wooden side rail (article number 274, width 95mm)	12 cm -17cm	
Continuous wooden side rail (article number 309, width 115mm)	12 cm -25cm	
2-part split Aluminium-side rail (article number BC 9.04.05763800)	12 cm -19cm	
3-part split steel side rails (article number BC 9.04.0435000)	12 cm -15cm	
Overall length	211,5cm (with 200cm long lying surface)	
Overall width	105cm (with 89cm wide lying surface)	
Height of upper edge of head/foot section	86,5 cm – approx.1129 cm	
Height adjustment of lying surface	electrically stepless up to approx. 24-80cm	
Backrest adjustment	electrically stepless up to approx.	70°
Thigh rest adjustment	electrically stepless up to approx.	30°
Foot elevation	mechanical, -25°to 0° in 5 steps	
Lying surface floor	Steel spring slats	
Wooden side rails incl. end caps can be lowered on both sides:	197,3 x 9,5 x 2,8cm or 197,3x 11,5 x 2,8cm	
Track rollers	Ø 100 mm with central brake	
Max. Track roller load capacity	100kg (static)	
Unladen weight of the bed	126kg	
materials	frame, lying surface etc: Headboard and footboard: Side rails: 2-part split side rails 3-part split side rails Electronic components:	steel (powder-coated) wood (veneered) wood (veneered) aluminium steel (powder-coated) plastic and aluminium

12. Technical specifications

12.2 Technical data (electrical)

Control + power supply SMPS	MC222+ MC115 (Limoss company)
Hand set	HC 145 or HC 146 (Limoss company)
Nominal voltage	230V
Nominal frequency	50/60Hz
Current type	AC~
Output SMPS	29V, 2,0A
Max. power consumption	2,1A
Rated recording in idle state	0,5 Watt
Switch-on cycle	Max. ED 2 Min. / Min. AD 18 Min (max. 5 switching cycles/ min.) 9V block battery (alkaline manganese 6LR61)
Emergency lowering battery	
Protection class	II
Protection class of the drives	IPX4 (protection against splashing water from all sides)
Operating noise	<52 db(A) at a distance of 1m
Reclining surface drive (back/knee)	2xMD125 (Limoss company)
Height adjustment drive	2xMD120 (Limoss company)

12.3 Technical data Environment

Operating temperature range	+10°C bis +40°C
Storage/transport temperature range	-10°C bis +60°C
Atmospheric humidity	30% bis 75% rel
Atmospheric pressure	between 795 and 1060 hPa

12.4 Classification

Medical device	Class 1
Degree of protection according to IEC 60601-1	Application part of type B (Protection against electric shock)
Housing protection class according to IEC 60529	IPX4 (protection against splashing water on all sides, but not suitable for wash tunnels)
Max. Duty cycle	10%, On 2Min/Off 18Min
Max. Switch-on cycles / min	5
Safety inspections	1x early



12.5 Weights of the individual components

Lying surface	49,00 kg
headend / footendpaneling	10,30 kg/piece
Lifting system	57,00 kg
Wooden side rail 115mm (4x)	11,00kg
Wooden side rail 95mm (4x)	10,50kg
Aluminium-side rail	06,20kg
Erector	4,20kg

12. Technical specifications

12.6 Identification plates



Identification plate

Position:

Glued to the right inside of the lying surface frame

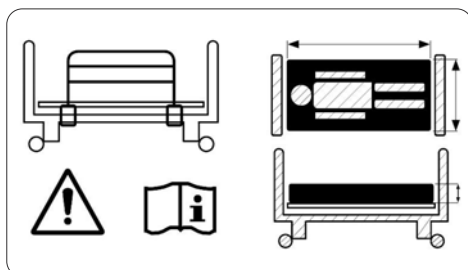

Note:

- 1) Exchangeable mattresses
- 2) Removable side rails

Position:

Frame upper side of the bed lifting frame at the foot side

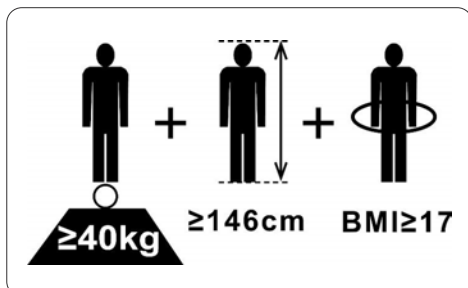

Note:

Use of the Cadence bed for adults

Position:

Frame upper side of the bed lifting frame at the foot side

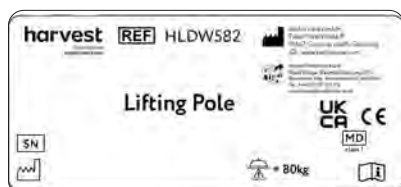

Identification plate

lifting pole (Accessories)

Position: lifting pole



Identification plate

Bed extension (Accessories)

Position:

Top side bed extension

12. Technical specifications

12.7 Information on electromagnetic compatibility

The Cadence bed range meets the normative requirements with regard to its electromagnetic interference emissions and its immunity to interference. Therefore, if the bed is used as intended, no functional restrictions are to be expected due to possible electromagnetic interference from adjacent electrical devices.



Attention:

Nevertheless, the use of the bed in the immediate vicinity of other electrical devices should be avoided in order to prevent the bed from malfunctioning due to electromagnetic interference. If it is necessary to use the bed in addition to other electrical devices, the proper functioning of the bed and these devices should be observed.



Only spare parts (mains cable, handset, motors, etc.) and accessories that have been approved by Harvest Healthcare may be used in order to be able to guarantee trouble-free operation of the bed.



The use of other accessories, other converters and other cables than those provided by Harvest Healthcare for this bed can result in increased electromagnetic interference emissions or reduced electromagnetic interference immunity of the bed and lead to faulty operation.



Portable HF communication devices (mobile phones, two-way radios, etc.) including their accessories (e.g. antenna cables and external antennas) should not be used within a distance of less than 30 cm from the electrical components and cables of the Cadence profiling bed. Non-observance can lead to a reduction in the performance characteristics of the bed.



The Cadence profiling bed is intended for use in the following specified electromagnetic environment during its entire service life in order to maintain basic safety and functional characteristics.



The operator or user of the bed should ensure that it is used in such an environment.

The Cadence profiling bed meets the requirements of the following EMC standards for interference emission and interference immunity:

Ambient limit values of the interference emissions	
Phenomenon	operation site in the field of medical care in a home environment
Conducted and radiated interference emissions	CISPR 11, Group 1, Class B
Harmonic distortions	see IEC 61000-3-2
Voltage fluctuations and flicker	see IEC 61000-3-3

Sheathing		
Phenomenon	EMC basic standard or test method	Immunity test level
Electrostatic discharge	IEC 61000-4-2	± 8 kV contact ± 2 kV, ± 4 kV, ± 8 kV, ± 15 kV air
High-frequency electromagnetic fields	IEC 61000-4-3	10 V/m ;(80 MHz up to 2,7 GHz; 80% AM at 1 kHz)
High-frequency electromagnetic fields in the immediate vicinity of wireless communication devices	IEC 61000-4-3	see table Test specifications for the immunity of sheathings to high-frequency wireless communication equipment (at the end of this chapter)
Magnetic fields with energetically rated frequencies	IEC 61000-4-8	30 A/m, 50 Hz or 60 Hz
Magnetic fields at close range	IEC 61000-4-39	no magnetically sensitive components, therefore no immunity rating required

12. Technical specifications

AC port for supply input		
Phenomenon	EMC basic standard or test method	Immunity test level
Short, transient electrical disturbances / bursts	IEC 61000-4-4	± 2 kV, 100 kHz repetition frequency
Surges: conductor to conductor	IEC 61000-4-5	$\pm 0,5$ kV, ± 1 kV
Conducted interference induced by high-frequency fields	IEC 61000-4-6	3 V 0,15 MHz up to 80 MHz 6 V in ISM and amateur radio frequency bands between 0,15 MHz and 80MHz 80 % AM at 1kHz
voltage dips	IEC 61000-4-11	0% U_T ; $\frac{1}{2}$ period at 0, 45, 90, 135, 180, 225, 270 and 315 degree
		0% U_T ; 1 period and 70% U_T ; 25/30 periods single-phase at 0 degree
voltage interruptions	IEC 61000-4-11	0% U_T ; 250/300 periods

DC port for supply input		
Phenomenon	EMC basic standard or test method	Immunity test level
Short, transient electrical disturbances / bursts	IEC 61000-4-4	± 2 kV 100 kHz repetition frequency
Surges: conductor to conductor	IEC 61000-4-5	$\pm 0,5$ kV, ± 1 kV
Surges: conductor to earth	IEC 61000-4-5	$\pm 0,5$ kV, ± 1 kV, ± 2 kV
Conducted interference induced by high-frequency fields	IEC 61000-4-6	3 V 0,15 MHz up to 80 MHz 6 V in ISM and amateur radio frequency bands between 0,15 MHz and 80MHz 80 % AM at 1kHz

Patients' connection ports		
Phenomenon	EMC basic standard or test method	Immunity test level
Electrostatic discharge	IEC 61000-4-2	± 8 kV contact ± 2 kV, ± 4 kV, ± 8 kV, ± 15 kV air
Conducted interference induced by high-frequency fields	IEC 61000-4-6	3 V 0,15 MHz up to 80 MHz 6 V in ISM and amateur radio frequency bands between 0,15 MHz and 80MHz 80 % AM at 1kHz

SIP/SOP-Tor (Signaleingangs-/Signalausgangsteilen)		
Phenomenon	EMC basic standard or test method	Immunity test level
Electrostatic discharge	IEC 61000-4-2	± 8 kV contact ± 2 kV, ± 4 kV, ± 8 kV, ± 15 kV air
Short, transient electrical disturbances / bursts	IEC 61000-4-4	± 1 kV 100 kHz repetition frequency
Conducted interference induced by high-frequency fields	IEC 61000-4-6	3 V 0,15 MHz up to 80 MHz 6 V in ISM and amateur radio frequency bands between 0,15 MHz and 80MHz 80 % AM at 1kHz

12. Technical specifications

Test specifications for the immunity of sheathings to high-frequency wireless communication equipment				
Test Frequency (MHz)	Frequency band (MHz)	Radioservice	Modulation	Immunity test level (v/m)
385	380 to 390	TETRA 400	Pulse modulation 18 Hz	27
450	430 to 470	GMRS 460, FRS 460	FM ± 5% lift, 1kHz sine	28
710	704 to 787	LTE band 13, 17	Pulse modulation 217 Hz	9
745				
780				
810	800 to 960	GSM 800/900, TETRA 800 iDEN820, CDMA 850, LTE Band 5	Pulse modulation 18 Hz	28
870				
930				
1720	1700 to 1990	GSM 1800, CDMA 1900, GSM 1900, DECT, LTE band 1;3; 4; 25; UMTS	Pulse modulation 217 Hz	28
1845				
1970				
2450	2400 to 2570	Bluetooth, WLAN 802.11 b/g/ n, RFID 2450, LTE band 7	Pulse modulation 217 Hz	28
5240	5100 to 5800	WLAN 802.11 a/n	Pulse modulation 217 Hz	9
5500				
5785				

The minimum distances for higher immunity test levels shall be calculated using the following equation.



$$E = \frac{6}{d} \sqrt{P}$$

P = maximum power in watts (W)

d = Minimum distance in meters (m)

E = Immunity test level in volts per meter (V/m)

If a test with these increased test levels is passed, the stated minimum distance of 30cm can be replaced by the new minimum distance calculated for the increased immunity test levels.



Sheaf House, Bradmarsh Way,
Bradmarsh Business Park,
Rotherham, S60 1BW

T +44 (0)1709 377 172
F +44 (0)1709 377 173
E sales@harvesthealthcare.co.uk
www.harvesthealthcare.co.uk



tecfor care GmbH
Fraunhoferstraße 8
51647 Gummersbach
Deutschland

Telefon: +49 2261 50186 0
Mail: info@tecfor-care.com
Web: www.tecfor-care.com